



# DUST SENSOR



DATASHEET



## GENERAL SPECIFICATION

Switching functions	normally open (NO)
Output type	NAMUR
Switching distance	sn 10mm
Installation	in one plane

## CHARACTERISTIC VALUE

Installation conditions	A – 0mm B – 0mm C – 20mm F – 60mm
Rated voltage (U <sub>o</sub> )	8,2 V (Ri cca. 1 kΩ)
Operating voltage (U <sub>b</sub> )	5 ... 15 V
Switching frequency	0 ... 50 Hz
Reverse polarity protection	reverse polarity protection
Consumption of electricity	the measuring plate has not been detected ≤ 1,5 mA measurement plate detection ≥ 2,5 mA
Switch status indication	LED yellow

## MECHANICAL SPECIFICATION

Connection type	device connector M12 x 1, 4 outlets
Housing material	Stainless Steel 1.4305 / AISI 303
Front surface	PTFE
Protection class	IP 67

## GENERAL INFORMATION

Use in explosion hazard area	see operating instruction
Category	1G, 1D





## COMPLIANCE WITH STANDARDS AND GUIDELINES

Compliance with standard	
NAMUR	EN 60947-5-6:2000 IEC 60947-5-6:1999
Normative	EN 60947-5-2:2007 IEC 60947-5-2:2007
Approvals and certificates	Certification ETL cETLus Approvals CCC - for products with a maximum operating voltage of 36V not need permission. Therefore, do not bear the CCC designation

## AMBIENT CONDITIONS



Ambient temperature	-20 ... 70 °C (-4 ... 158 °F)
---------------------	-------------------------------

## EQUIPMENT PROTECTION LEVEL Ga

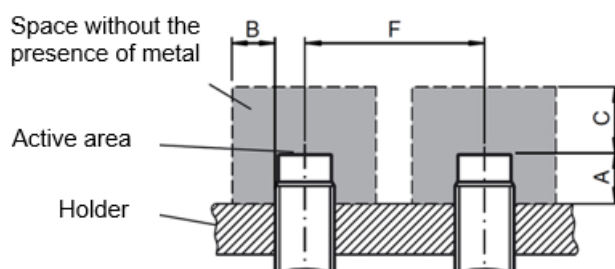
Instruction	Electrical equipment for areas with risk of explosion <sub>3</sub>
Category of equipment	For use in potentially explosive atmospheres containing gas, steam, spray mist
The EC type examination certificate	BVS 13 ATEX E 074 X
ATEX labeling	II 1G Ex ia IIC T1 – T6 Ga
Labeling	0102
Normative	EN 60079-0:2012 EN 60079-11:2012 EN60079-26:2007 The degree of protection against inflammation is typical of its own safety
Appropriate type	CCB10-30GS55 – N1...
Effective internal inductance	$C_i \leq 250 \text{ nF}$ $L_i \leq 200 \text{ }\mu\text{H}$
Generals	The device must be operated in accordance with the data in the technical data sheet and in accordance with these operating instructions. The EU type-examination certificate must be adhered to. Special conditions must be met! The ATEX Directive generally applies only to the use of electrical equipment under atmospheric conditions. When using electrical equipment outside the atmospheric conditions, the possible reduction of permissible ignition energy must be taken into account.
Maximum permissible ambient temperature	T6: $P_i = 100 \text{ mW}$ , $U_i = 15 \text{ V}$ , $I_i = 30 \text{ mA}$ 40 °C (104 °F) T5: $P_i = 100 \text{ mW}$ , $U_i = 15 \text{ V}$ , $I_i = 30 \text{ mA}$ 40 °C (104 °F) T4: $P_i = 100 \text{ mW}$ , $U_i = 15 \text{ V}$ , $I_i = 30 \text{ mA}$ 80 °C (176 °F) T3, T2, T1: $P_i = 100 \text{ mW}$ , $U_i = 15 \text{ V}$ , $I_i = 30 \text{ mA}$ 80 °C (176 °F)





EQUIPMENT PROTECTION LEVEL Da	
Instruction	Electrical equipment for areas with risk of explosion
<b>Category of equipment 1D</b>	<b>For use in potentially explosive atmospheres containing flammable dust</b>
The EC type examination certificate	BVS 13 ATEX E 074 X
ATEX labeling	 II 1D Ex ia III C T101°C Da
Labeling	 0102
Normative	EN 60079-0:2012 EN 60079-11:2012 The degree of protection against inflammation is typical of its own safety "ia"
Appropriate type	CCB10-30GS55 – N1...
Effective internal inductance	$C_i \leq 250 \text{ nF}$ $L_i \leq 200 \text{ }\mu\text{H}$
General operation	The device must be operated in accordance with the data in the technical data sheet and in accordance with these operating instructions. The EU type-examination certificate must be adhered to. Special conditions must be met!
Permissible range of ambient temperatures	-20 ... 90°C (-4 ... 194 °F)





# Fire and explosion protection

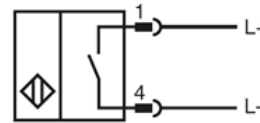
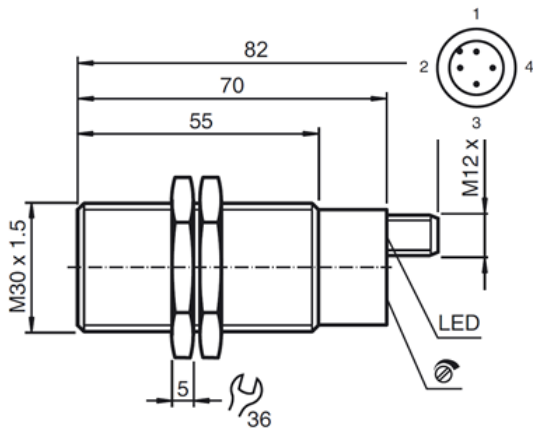

If installed in an explosion zone, it must be connected via an intrinsically safe circuit (eg intrinsically safe relay), see below.

## Intrinsically safe relay – STAHL 9170/xx-xx-xx

11-11-11 24V	1 - channel, relay output (signal) 3G/3D*
21-11-11 24V	2 - channel, relay output (signal) 3G/3D*
21-10-11 24V	2 - channel, relay output (signal) 3G/3D*
11-11-21 230V	1 - channel, relay output (signal)
21-11-21 230V	2 - channel, relay output (signal)
21-10-21 230V	2 - channel, relay output (signal)
11-12-11 24V	1 - channel, relay output (power)
21-12-11 24V	2 - channel, relay output (power)
11-12-21 230V	1 - channel, electronic
21-12-21 230V	2 - channel, electronic
11-14-11 24V	1 - channel, electronic 3G/3D*
21-14-11 24V	2 - channel, electronic 3G/3D*
11-14-12 24V	1 - channel, electronic LFT 3G/3D*
21-14-12 24V	2 - channel, electronic LFT 3G/3D*

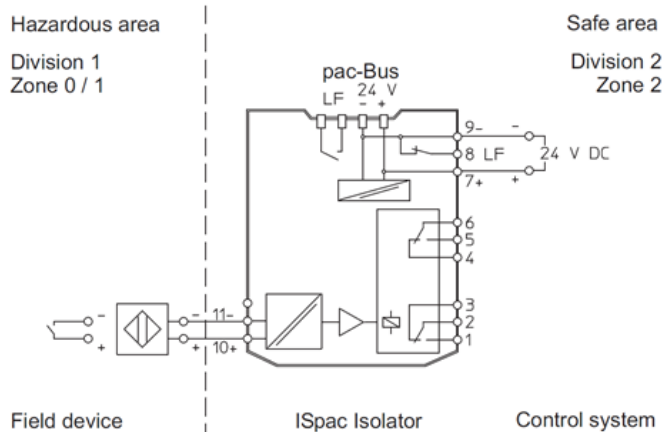

# DATASHEET

## Connection box

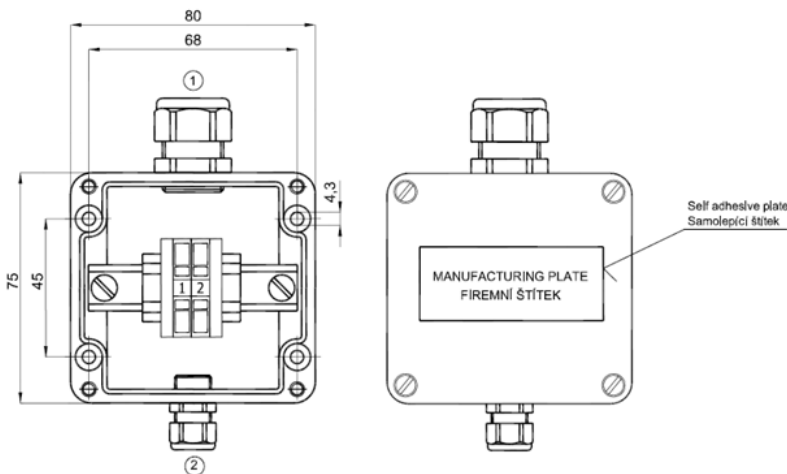

Connection in a box installed on the outer shell of the flap





# Fire and explosion protection

## POSITION INDICATOR

DATASHEET

### Installation:

- Observe the relevant national laws and regulations.
- Avoid electrostatic charges on plastic units and cables.
- Protect the device and the cable from damage.
- Units are not suitable for wall mounting that separate zone 0 from zone 1.
- The appropriate electrical installation regulations must be observed.
- Equipotential bonding of the metal sheath parts must be ensured by suitable mounting
- If installed in an explosion zone, it must be connected via a safe circuit (eg intrinsically safe relay)
- Interconnection in the box installed on the outer shell of the flap



### Product properties:

Inductive Sensor, Metal Thread, M8 x 1, Connected to Proven, Secured Current Circuit, Highest Value U = 15 V / I = 50 mA / P = 120 mW, ATEX certificate, Group II, category 1D / 1G, Cable design, Switching distance 1 mm [b].

### ELECTRICAL DATA

Electrical connection	Connection to the proven, secured circuit with the highest value U = 15 V / I = 50 mA / P = 120 mW
Rated voltage [V]	8,2 DC (1Ω)
Connection voltage [V]	7,5 ... 30 DC, when used outside the Ex zone
Current consumption [mA]	< 1 disconnection; (> 2,1 mA lead)
Cover class	III.

### OUTPUTS

Output functions	switch
Current carrying capacity [mA]	< 30, when used outside the Ex zone
Switching frequency [Hz]	2000

### RESEARCH AREA

Switching distance [mm]	1
Real switching distance (Sr) [mm]	1 ± 10 %



# Fire and explosion protection



# DATASHEET





## ACCURACY / DEVIATIONS

Correction factors	steel (St37) = 1 / V2A ca. 0,7 / Ms ca. 0,5 / Al ca. 0,4 / Cu ca. 0,3
Hysteresis [% ze Sr]	1 ... 15
Deviation of switch point [% ze Sr]	-10 ... 10

## AMBIENT CONDITIONS

Ambient temperature [°C]	-20 ... 80
Cover	IP 67

## APPROVAL / TESTS

Certificate	PTB 01 ATEX 2191 BVS 04 ATEX E153
Device designation	 II 1G Ex ia IIC T6 Ga Ta: -20...70° C  II 1G Ex ia IIC T5 Ga Ta: -20...80° C  II 1D Ex ia IIIC T90° C Da Ta: -20...70° C  II 1D Ex ia IIIC T100° C Da Ta: -20...80° C
Electromagnetic Compatibility	EN 60947-5-6
Impact resistance / vibrations	30 g (11 ms) / 10-55 Hz (1 mm)
MTTF [years]	6204

## SAFETY RATED VALUES

Own capacity [ nF ]	< 80
Own inductivity [ μH ]	< 70

## MECHANICAL DATA

The way of installation	Coupling installation
Housing material	Brass specially coated, surface active. PBT
Weight [kg]	0,092

## ELECTRICAL CONNECTION

Connection	PVC-Cable / 2 m; 2 x 0,14 mm <sup>2</sup>
------------	---





# Fire and explosion protection

# DATASHEET



## CONNECTION OF CONTACTS

Color of wires:	BN brown BU blue
-----------------	---------------------

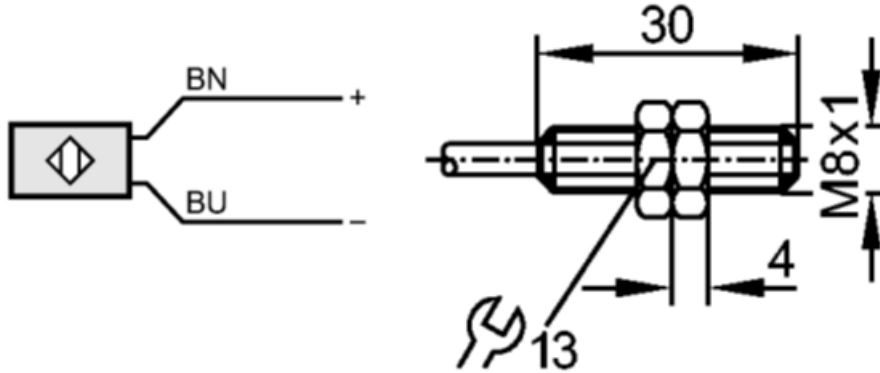

11-11-11 24V	1 - channel, relay output (signal) 3G/3D*
21-11-11 24V	2 - channel, relay output (signal) 3G/3D*
21-10-11 24V	2 - channel, relay output (signal) 3G/3D*
11-11-21 230V	1 - channel, relay output (signal)
21-11-21 230V	2 - channel, relay output (signal)
21-10-21 230V	2 - channel, relay output (signal)
11-12-11 24V	1 - channel, relay output (power)
21-12-11 24V	2 - channel, relay output (power)
11-12-21 230V	1 - channel, electronic
21-12-21 230V	2 - channel, electronic
11-14-11 24V	1 - channel, electronic 3G/3D*
21-14-11 24V	2 - channel, electronic 3G/3D*
11-14-12 24V	1 - channel, electronic LFT 3G/3D*
21-14-12 24V	2 - channel, electronic LFT 3G/3D*

### Intrinsic safety

Hazardous area  
Division 1  
Zone 0 / 1

Safe area  
Division 2  
Zone 2

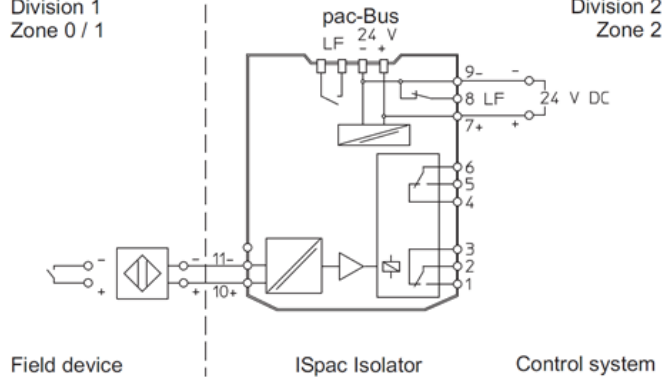

### Connection box

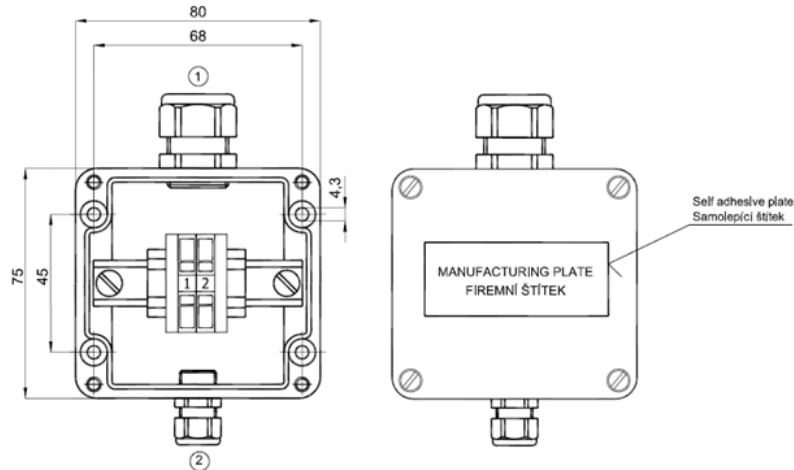



# Fire and explosion protection

## SEAL (B-FLAP I, FLEX, VMP)

This datasheet describes the technical specifications for seal types for B-Flap, Flex and VMP products.

In case of customer OR application) it is possible to supply the seal in an alternative material (see below).

### EPDM MATERIAL SEAL (optional accessories)

EPDM MATERIAL CLASSIFICATION	
Standard color	Black
Hardness t	50 ShA (max. 80 ShA)
Density	cca 1,25 g/cm <sup>3</sup>
Tensile strength	5 MPa
Elongation at break	400%
Operating temperature	-40°C to 120°C

### SILICONE MATERIAL SEAL (optional accessories)

SILICONE MATERIAL CLASSIFICATION	
Standard color	White / transparent / red
Hardness t	60 ShA
Density	1,19 g/cm <sup>3</sup>
Tensile strength	6 MPa
Elongation at break	320%
Operating temperature	-60°C to 230°C (short-term to 280°C)

The material corresponds FDA 21§177.2600, BGVV/WRC/KTW; attest ITC Zlín

### TEMASIL HT MATERIAL SEAL (optional accessories)

TEMASIL HT MATERIAL CLASSIFICATION	
Standard color	Light blue
Maximum pressure	120 bar
Density	1,8 g/cm <sup>3</sup>
Compressibility	10%
Operating temperature	-30°C to 330°C (short-term to 450°C)

DATA SHEET

