



Fire and explosion protection

EXPLOSION ISOLATION FLAP VALVE B-FLAP I

In the event that the technology exists explosive atmosphere in the form of a swirling cloud of dust and assuming this cloud contact with an ignition source may cause an immediate explosion.

The B-FLAP I device is used to separate individual devices and prevent explosion transfer from one part of the technology to the other connecting pipe. B-FLAP I is installed on this pipeline and allows the passage of the air with the conveyed material in only one direction. Increased (explosive) pressure acting in the second direction of B-FLAP I closes and prevents the transfer of flame, fumes, and explosive pressure down the pipeline into the next part of the technology, which could further spread the devastating effect of the explosion. After closing the B-FLAP I, the locking element remains locked firmly until the operator arrives.

The explosion isolation flap valve B-FLAP I is designed in accordance with European Directive 2014/34 / EU, based on EN 16447. The B-FLAP I falls within the device group II, for the zone inside the flap 20 and outside the flap 21.



DATA SHEET



MATERIAL DESIGN	
Body	Composite structural steel, RAL 3000 (fiery red). Other color designs, depending on the customer's wishes. Optionally all-stainless-steel design.
Flange gasket	EPDM Supplied with B-FLAP I
Connecting material	Always included. For galvanized steel construction, galvanized finish, for stainless steel the connecting material is stainless steel.
Flange	According to the standard DIN EN 12 220 - R1 (DN 100 to DN 500), R2 (DN 560 to DN 800)

OPTIONAL ACCESSORIES	
Position indicator	Inductive sensor for B-FLAP I signaling. The sensor is equipped with ATEX certification and is connected to an intrinsically safe relay.
Dust sensor	Sensor to indicate dirt contact B-FLAP I, connecting over the intrinsically safe relay.
Intrinsically safe relay	It creates an interface between a safe and a dangerous zone.
Special flange gasket	In addition to a standard flange seal, it is also possible to supply seals made of special materials that suit exactly the customer's application.
Anti-abrasion coating	The coat flap protecting against abrasion.
Increase operating temperature	It is possible to increase the allowed operating temperature to 150 °C (DN 100 to DN 630)

TEMPERATURE CHARACTERISTIC B-FLAP I	
Ambient temperature	-40 to 80 °C
Operating temperature	-40 to 80 °C
Storage temperature	10 to 40 °C





Type	Code	ØA [mm] [in]	ØB [mm] [in]	ØC [mm] [in]	D x ØE	L [mm] [in]	N [mm] [in]	P [mm] [in]	Weight [kg]	$p_{red,max}$ [bar]	Explosive class	Installation distance	Pressure resistance p_{max} [bar]	Pressure loss at 20 m/s [Pa]
DN 100	K-ZKL-100-ST1 K-ZKL-100-ST2	152 (6)	132 (5,2)	100 (3,9)	4 x 9,5	280 (11)	287 (11,3)	244 (9,6)	9	0,6	St1, St2	3 - 7	1	350
DN 125	K-ZKL-125-ST1 K-ZKL-125-ST2	177 (7)	157 (6,2)	125 (4,9)	4 x 9,5	305 (12)	308 (12,1)	269 (10,6)	11	0,6	St1, St2	3 - 7	1	215
DN 150	K-ZKL-150-ST1 K-ZKL-150-ST2	202 (8)	182 (7,2)	150 (5,9)	6 x 9,5	330 (13)	337 (13,3)	294 (11,6)	13	0,6	St1, St2	3 - 7	1	220
DN 200	K-ZKL-200-ST1 K-ZKL-200-ST2	253 (10)	233 (9,2)	200 (7,9)	6 x 9,5	390 (15,4)	387 (15,2)	344 (13,5)	18	0,6	St1, St2	3 - 7	1	230
DN 250	K-ZKL-250-ST1 K-ZKL-250-ST2	303 (11,9)	283 (11,1)	250 (9,8)	6 x 9,5	510 (20,1)	502 (19,8)	417 (16,4)	40	0,45	St1, St2	4 - 7	0,65	270
DN 300	K-ZKL-300-ST1 K-ZKL-300-ST2	363 (14,3)	337 (13,3)	300 (11,8)	8 x 9,5	580 (22,8)	552 (21,8)	467 (18,4)	50	0,45	St1, St2	4 - 7	0,65	270
DN 315	K-ZKL-315-ST1 K-ZKL-315-ST2	378 (14,9)	352 (13,9)	315 (12,4)	8 x 9,5	600 (23,6)	567 (22,3)	482 (19)	53	0,45	St1, St2	4 - 7	0,65	290
DN 355	K-ZKL-355-ST1 K-ZKL-355-ST2	418 (16,5)	392 (15,4)	355 (14)	8 x 9,5	630 (24,8)	607 (23,9)	522 (20,6)	61	0,45	St1, St2	4 - 7	0,65	320
DN 400	K-ZKL-400-ST1 K-ZKL-400-ST2	464 (18,3)	438 (17,2)	400 (15,7)	8 x 9,5	695 (27,4)	652 (25,7)	568 (22,4)	77	0,45	St1, St2	4 - 7	0,65	330
DN 450	K-ZKL-450-ST1	514 (20,2)	488 (19,2)	450 (17,7)	8 x 9,5	750 (29,5)	702 (27,6)	619 (24,4)	88	0,35	St1	4 - 7	0,8	450
DN 500	K-ZKL-500-ST1	564 (22,2)	538 (21,2)	500 (19,7)	8 x 9,5	800 (31,5)	752 (29,6)	559 (26,3)	101	0,35	St1	4 - 7	0,8	500
DN 560	K-ZKL-560-ST1	664 (26,1)	629 (24,8)	560 (22)	16 x 14	930 (36,6)	838 (33)	745 (29,3)	157	0,45	St1	4 - 7	0,8	500
DN 630	K-ZKL-630-ST1	734 (28,9)	698 (27,5)	630 (24,8)	16 x 14	1005 (39,6)	908 (35,7)	815 (32,1)	180	0,45	St1	4 - 7	0,8	550
DN 710	K-ZKL-710-ST1	814 (32)	775 (30,5)	710 (28)	16 x 14	1156 (45,5)	1102 (43,4)	967 (38,1)	305	0,45	St1	3 - 7	0,7	500
DN 800	K-ZKL-800-ST1	904 (35,6)	861 (33,9)	800 (31,5)	24 x 14	1246 (49)	1193 (47)	1057 (41,6)	351	0,45	St1	3 - 7	0,7	500

Basic dimensions:

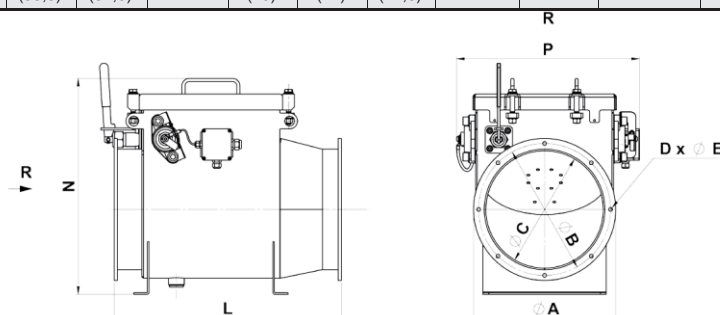

Basic parts:

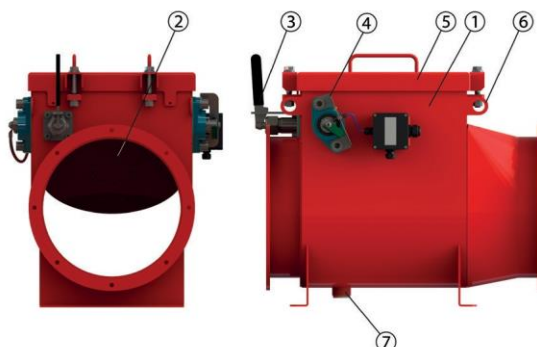

- 1) Welded body
- 2) Sealing part
- 3) Locking mechanism
- 4) Position indicator
- 5) Welded lid
- 6) Lifting eyes
- 7) Preparation for dust sensor

